

INTERLOCK INSTRUCTION MANUAL

Work **SAFE** For **LIFE**™



Kirk Key Interlock Company

9048 Meridian Circle NW, North Canton, OH 44720

Phone: 234.209.9301 • Fax: 330.497.4400

Toll Free: 1.800.438.2442

www.kirkkey.com

Table of Contents:	Type F, FN, B, NT, T, U, FR	Page 2	Table of Contents:
	Type D, DM, DY	Page 3-5	
	Transfer Panel.....	Page 6	
	Type S and Type K Auxiliary Switches.....	Page 7	
	Type TPS and Dust Covers.....	Page 8	
	Key Control and Duplicate Keys.....	Page 9	
	Service and Maintenance.....	Page 10	
Duplicate Key Release Form.....	Page 11-12		

Installation Instructions

Proper installation of key interlocks is a critical element of a key interlock system. It is essential that each interlock be installed so that the lock bolt cannot be extended unless the equipment on which it is installed is in the proper position/condition. After installation of the interlocks, the complete interlock system should be tested sequentially by person(s) familiar with the entire system, the key routing, and its intended purpose. Any problems or discrepancies must be corrected prior to energization.

Each interlock is supplied with a key in each cylinder. These keys are needed during installation of the interlocks. Once the complete interlock system is installed, all extra keys must be removed from the system and destroyed or retained by a responsible person. There should only be enough keys to operate the interlock system sequentially. Kirk Key Interlock Company will not be responsible for extra keys left in the interlock system.

Key interlocks with multiple cylinders require the insertion of all keys before the lock bolt can be extended or withdrawn. Likewise, transfer blocks and transfer panels (which do not have exposed lock bolts) require insertion of all keys before the operating bolt can be extended or withdrawn allowing release of previously held keys. Do not try to force a multiple cylinder interlock that does not have the correct keys fully inserted in every cylinder!

INTERLOCK INSTRUCTION MANUAL

Work **SAFE** For **LIFE**™



All KIRK Key Interlocks (Type F, FN, B, NT, T, U, FR)

The key interlock should be mounted so that the 5/8" lock bolt can be extended to lock the device in the proper position. In the unlocked position, the lock bolt should be blocked from extending, thereby trapping the key(s) in the interlock.

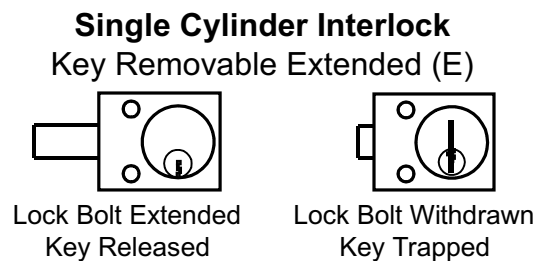
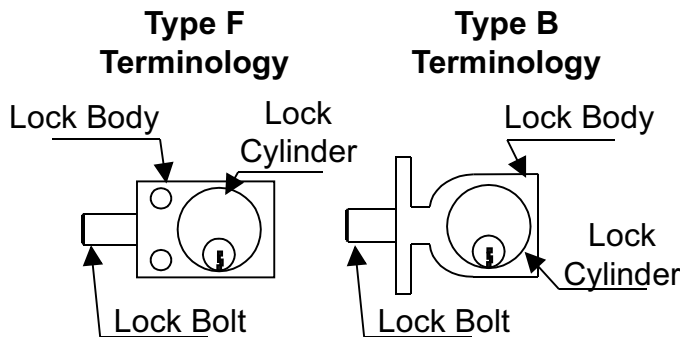

Multiple cylinder interlocks can be designed to retain one or more keys while the remaining keys are withdrawn.

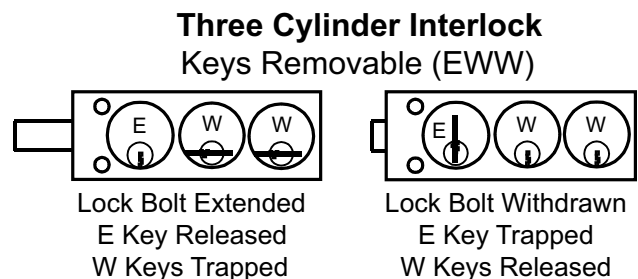
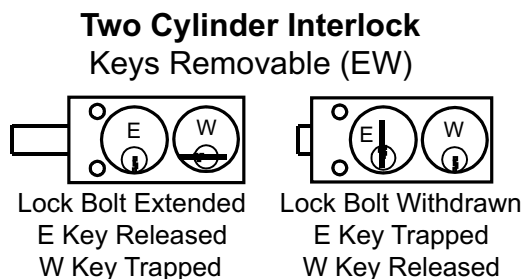
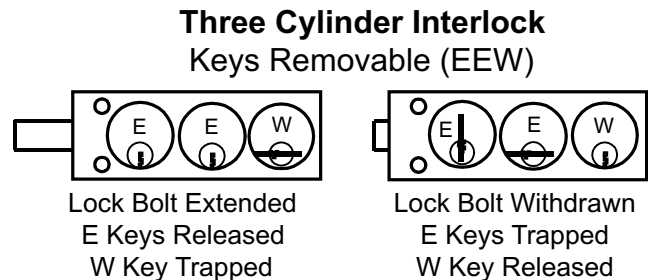
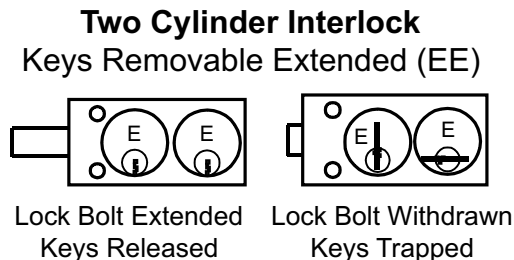

Key interlocks with multiple cylinders require the insertion of all keys before the lock bolt can be extended or withdrawn allowing release of the previously held keys. Do not try to force a multiple cylinder interlock that does not have the correct keys fully inserted in every cylinder.

INTERLOCK INSTRUCTION MANUAL

Work **SAFE** For **LIFE**™



KIRK Door/Access Interlocks (Type D, Type DM, Type DY)

Type D Door Interlock

All Type D interlocks have two parts: a main body with one or more cylinders and a latch block. Proper alignment of both parts is crucial to the operation of a Type D interlock. When the main body is separated from the latch block, the lock bolt is retained in the withdrawn position by concealed latch pins. Thus the key(s) is always held in the lock whenever the two parts are separated. When the door on which the interlock is mounted is properly closed, the key(s) can be turned to extend the lock bolt into the latch block, securing the door. Only extending the lock bolt, after properly closing the door, should allow release of the key(s). An exception to this rule is a multiple cylinder Type D interlock which allows release of a "personnel" key when the door is opened. The personnel key can be put in the pocket of the maintenance person ensuring that the door cannot be closed and locked as long as he holds the personnel key.

Type D Terminology

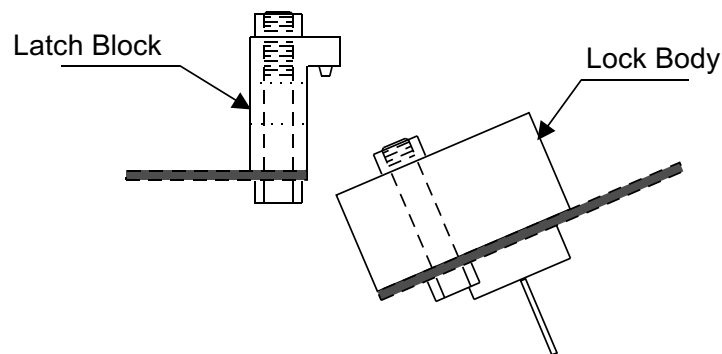

The key is trapped in type D interlock when the door is open.

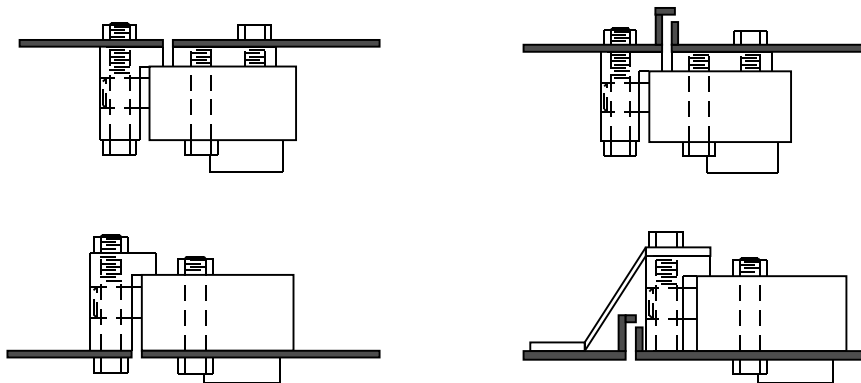

Mounting Options for Type D Locks and Latch Blocks

KIRK door interlocks should not be used to align the door, or be the latching means for holding the door in the closed position. Type DM or DY interlocks should be utilized in situations where the door and door-frame are ill-fitting, and a degree of latitude is required.

INTERLOCK INSTRUCTION MANUAL

Work **SAFE** For **LIFE**™



Type DM Access Door Interlock

All Type DM interlocks have two parts: a main body with one or two cylinders and a latch bolt with chain. When the latch bolt is separated from the main body, the key(s) is trapped in the lock. When the door on which the interlock is mounted is properly closed, the latch bolt can be inserted into the main body and the key can be turned and released.

Weld or bolt the chain to the door or door-frame allowing enough slack to insert and turn the latch bolt in the Type DM lock body when the door is properly closed.

DM Terminology and Operating Instructions

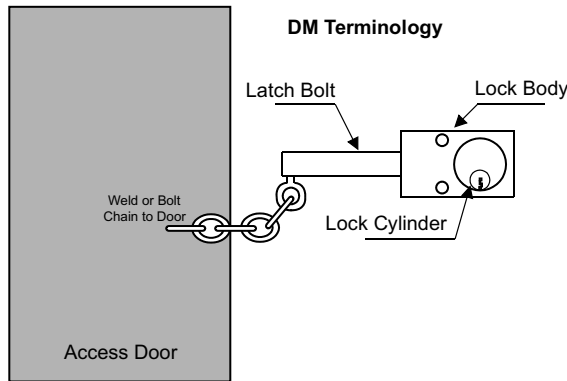

Single Cylinder DM Instructions

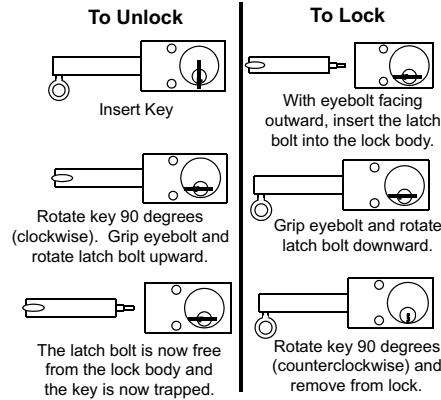

Two Cylinder DM (EE) Instructions

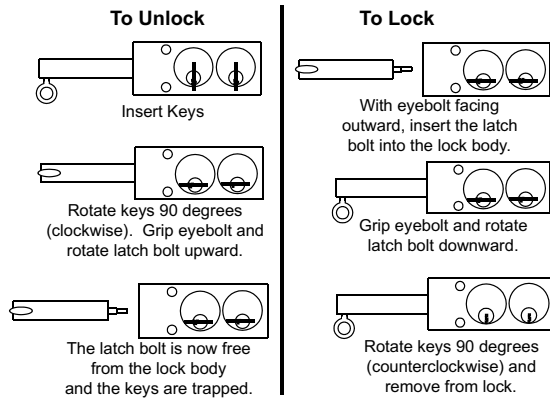

Two Cylinder DM (with Personnel Key) (EW) Instructions

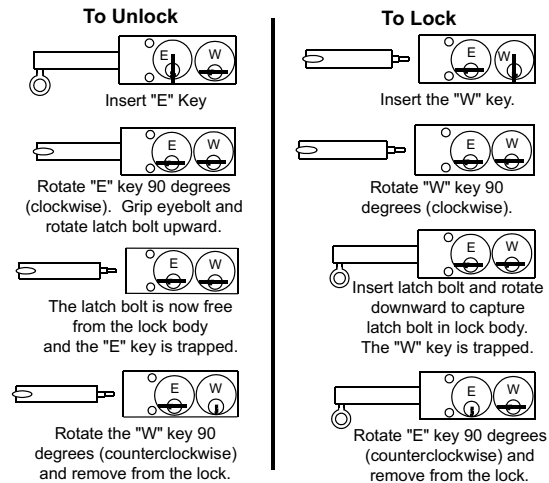

The "E" keys can be turned and released when the latch bolt is latched and the "W" keys can be turned and released when the latch bolt is unlatched.

INTERLOCK INSTRUCTION MANUAL

Work **SAFE** For **LIFE**™



Type DY Access Door Interlock

All Type DY interlocks have two parts: a main body and a latch block-bolt eye. When the main body is separated from the latch block-bolt eye, the key is retained and cannot turn in the lock. Thus, the key is always held in the lock when the two parts are separated.

Once the door or gate is closed and the latch block bolt-eye is engaged with the main body of the lock, the key can be turned and released.

Side View - DY Interlock & Latch Block-Bolt Eye

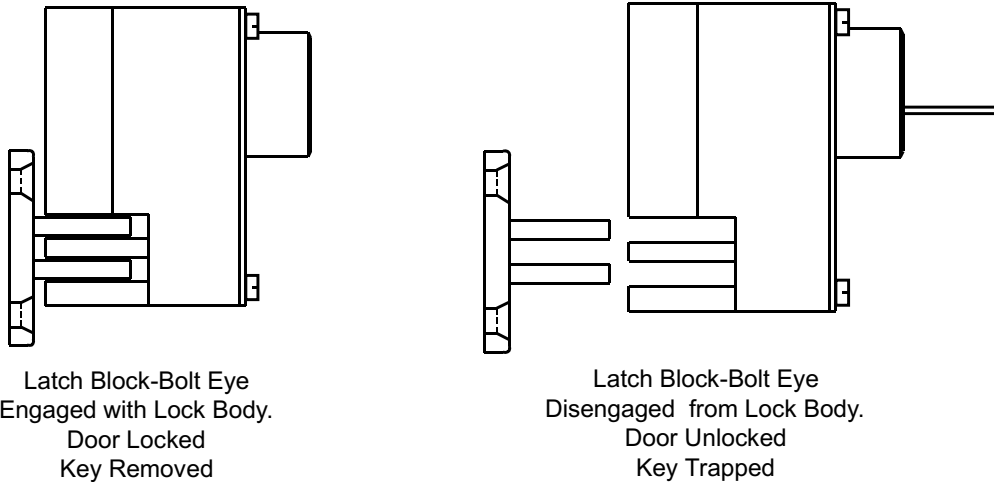

The latch block-bolt eye can be attached directly to the door jamb or fastened to a chain that is attached to the door frame as shown in the drawing below.

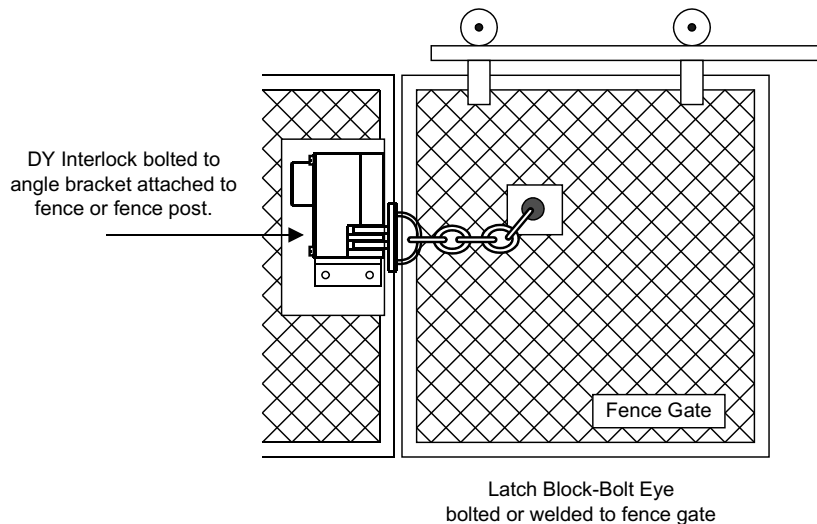

INTERLOCK INSTRUCTION MANUAL

Work **SAFE** For **LIFE**™



KIRK® Key Transfer Panels

A transfer panel is a group of primary and secondary locks involved in a transfer step. All primary keys must be inserted in the transfer panel and turned before any secondary keys can be released. Primary keys are generally related to power sources (such as breakers, T/R switches, level detectors, etc.) and secondary keys are related to access doors.

In the normal operating position, all secondary keys are “trapped” in the transfer panel and all primary keys are “trapped” in upstream equipment. All upstream equipment must be locked safe in order to release the keys for insertion in the primary side of the transfer panel. The secondary keys are then released allowing access to equipment (such as hopper doors, manholes, access doors). Access doors must make use of key retaining interlocks, such as the Type D, DY, or DM so that the secondary keys are trapped at the access point until the access openings are properly closed.

Two or more transfer scheme systems can be provided in one transfer panel enclosure however most enclosures are designed to house a single system.

It is important that the installer understand the entire key interlock system(s) and the intended purpose.

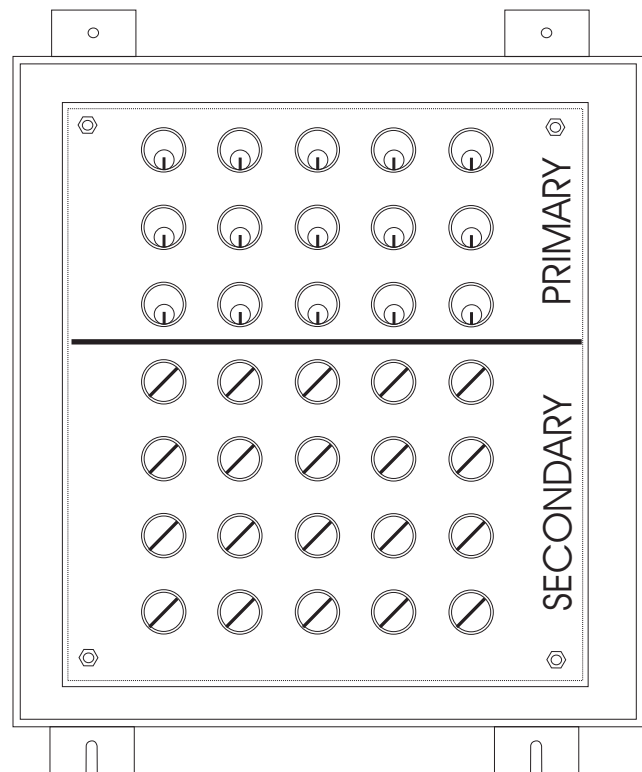

INTERLOCK INSTRUCTION MANUAL

Work **SAFE** For **LIFE**™



Wiring of Type S Auxiliary Switches

Denoted by a “3”, “4”, “5”, or “6” in column four of the interlock part number. (EX. KFL ③00010S-CM)

Auxiliary switches are an option for most styles of interlocks. Four different styles of slow-make, slow-break S switches are available as shown by the chart below.

Type of Switch	Type S	Type SS	Type SSS	Type SSSS
Number of Circuits	2	4	6	8
Make Contacts	1	2	3	4
Break Contacts	1	2	3	4
Conduit Opening	3/4"	1"	1"	1"
Length of Switch Housing	3-1/2"	5-3/4"	8-1/4"	9-5/8"
Contact Arrangement: The Set of Contacts Nearest the Lock Bolt are Closed when the Lock Bolt is Extended and Open when the Lock Bolt is Withdrawn				

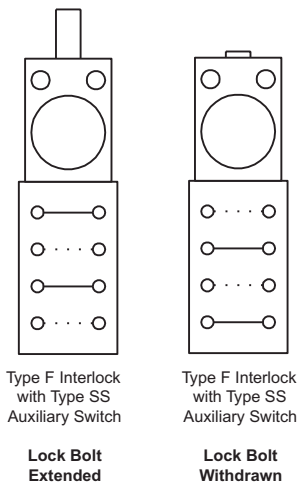

Instructions for wiring Type S switches:

- 1) Remove the cover.
- 2) Run wires into the switch housing and terminate on appropriate terminals.
- 3) Replace the switch cover.
- 4) Test the wiring to verify that the circuitry corresponds to the proper lock bolt position.

Wiring of Type K Auxiliary Switches

Denoted by a “1” in column four of the interlock part number. (EX. KFL ①00010S-CM)

The Type K auxiliary switch is an option that is available for most styles of interlocks. The Type K is normally a DPDT, quick-make, quick-break toggle switch. (Note: other styles of toggle switches are available by special order) **Contact Arrangement:**

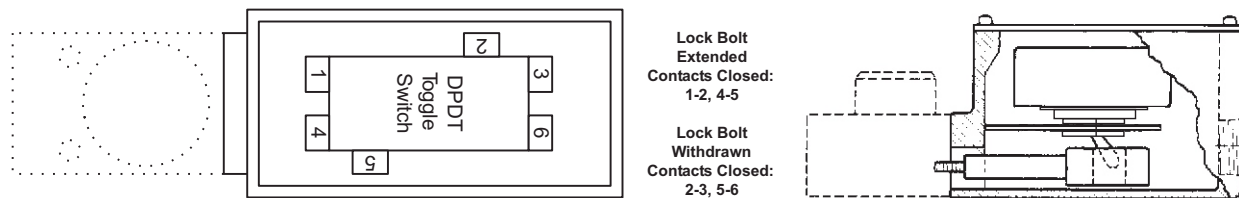

Instructions for wiring the Type K Switch:

- 1) Remove the cover.
- 2) Remove the toggle switch (three screws).
- 3) Run the wires into the switch housing and terminate on the appropriate terminals.
- 4) Reattach the toggle switch to the housing (three screws).
- 5) Replace the switch cover.
- 6) Test the wiring to verify that the circuitry corresponds to the proper lock bolt position.

Note: The Type S and Type K Auxiliary switches cannot be added to existing interlocks in the field.

INTERLOCK INSTRUCTION MANUAL

Work **SAFE** For **LIFE**[™]



Wiring of Type TPS (and TPSS) Interlock Switches

The type TPS interlock is a key actuated switch designed for back-panel mounting. The TPS has two normally open and two normally closed contacts and the TPSS has four normally open and four normally closed contacts. The contact blocks are clearly marked with the status of the contacts. After wiring, the installer must test the wiring to verify that the circuitry corresponds to the key position (trapped vs. free).

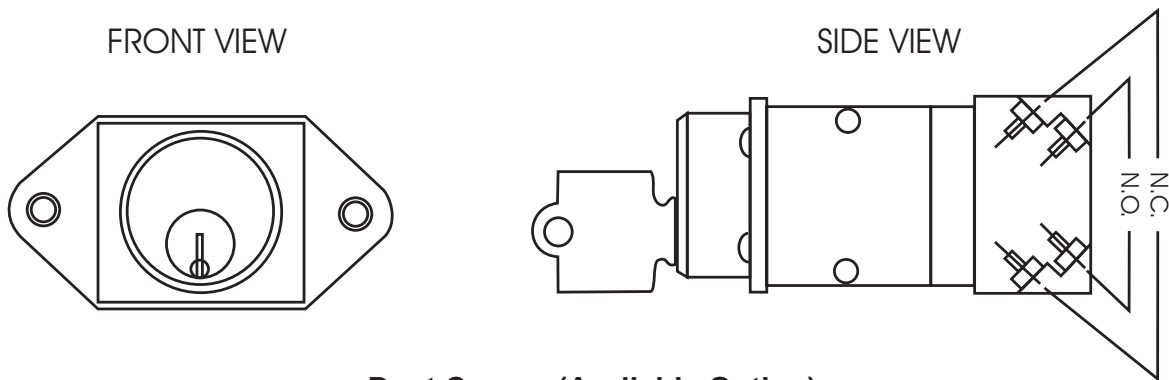

Dust Covers (Available Option)

Two Styles of dust covers are available to protect the lock cylinder and key against moisture, dirt, and sleet.

The Push On dust cover slips tightly over the lock cylinder when the key is in the held position or removed. The Push On dust cover is supplied with a chain and mounting ring, which is secured under the interlock mounting bolt head.

The Flip Open dust cover is designed to provide protection to the lock cylinder and key regardless of the position of the key. The Flip Open dust cover is hinged and held closed with spring tension. A single set-screw attaches the Flip Open dust cover to the lock cylinder.

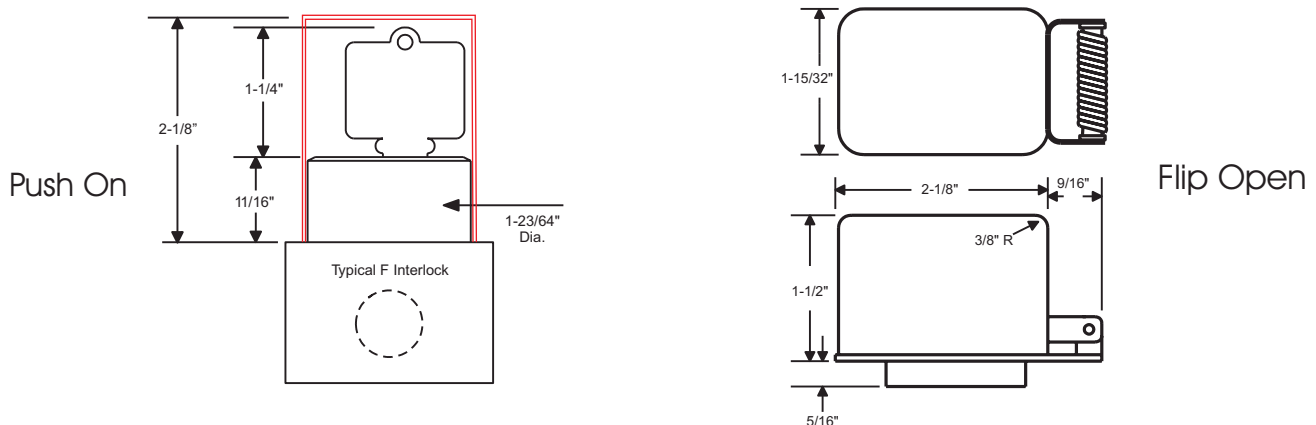

INTERLOCK INSTRUCTION MANUAL

Work **SAFE** For **LIFE**™



Key Control

IMPORTANT - To ensure correct operation of the KIRK® interlock system it is necessary to remove all loosely or removably held keys before operating the equipment on which the interlocks are mounted. There should only be enough keys to operate the interlock system sequentially.

The keys removed from the KIRK® interlocks should be returned to Kirk Key Interlock Company, North Canton, Ohio, or retained by authorized personnel for use as spare keys.

The spare keys must not be normally available to operating personnel, since the use of these keys, where not specifically required, will result in incorrect operation of the equipment on which the interlocks are mounted. Any spare keys should be given to operating personnel only, if and when the corresponding operating key has been destroyed.

ADDITIONAL KEYS will be provided **ONLY** with proper authorization from the ultimate user to which the specific key combination has been assigned.

Duplicate Keys

Each interlock is supplied with a key in its lock. These keys are needed during installation of the interlocks on equipment. This then provides more keys than are actually necessary for operation of the interlock system.

When the interlocks have been installed, all extra keys should be removed from the system and destroyed or retained by authorized personnel. If additional keys are required because of loss or damage, they can be supplied only on the purchaser's authorized order. To order additional or replacement keys, please:

- 1) Copy the duplicate key release form on pages 11 and 12 of this manual, or print from <http://www.kirkkey.com>.
- 2) Complete the form and sign your name.
- 3) Fax the form to Kirk Key Interlock Company for immediate delivery, at 330-833-1528.

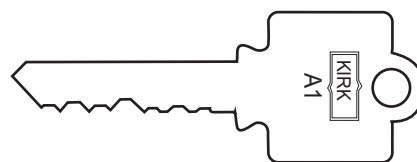
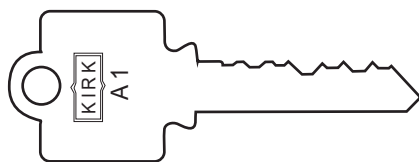

INTERLOCK INSTRUCTION MANUAL

Work **SAFE** For **LIFE**[™]



Service and Maintenance

Lubrication - Interlocks should be periodically lubricated with a small amount of dry powdered graphite. **Do not use oil of any type** as the oil will collect dirt and "foul" the lock cylinder so that it will not operate. Apply a small amount of graphite to the key and insert the key into the lock cylinder. Work the key in and out and turn the key several times in order to distribute the graphite inside the lock cylinder. **Kirk Key Interlock Company cannot warranty interlocks that have been oiled.**

Kirk Key Interlock Company offers a Graphite Lubrication Kit (part number GL-1) complete with instructions for use. The powdered graphite is supplied in a plastic tube that can be "squeezed" to force a small amount of graphite into the lock cylinder. As described above, work the key in and out and turn the key a few times in order to distribute the graphite inside the lock cylinder.

NOTE: Stainless steel dust covers should be utilized to protect the lock cylinders when located outdoors or in a demanding environment. Dust covers are available separately and can be easily added to any interlock.

Factory Service - Under normal operating conditions, KIRK[®] interlocks should not require any maintenance service, other than graphite lubrication. However, if refurbishment or replacement should be required, contact Kirk Key Interlock Company, North Canton, Ohio. All factory service will be performed as quickly as possible to minimize your down time.

Any damaged or malfunctioning interlock should be returned to Kirk Key Interlock Company, North Canton, Ohio. If this is not possible and replacement locks are required, the following information must be forwarded to Kirk Key Interlock Company:

- 1) Lock Number - obtain from the face of lock cylinder.
- 2) S.O. Number - obtain from nameplate on interlock
- 3) Item Number - obtain from nameplate on interlock
- 4) Key Interchange Number (if applicable) - obtain from the face of lock cylinder.

