

# Type U

## Isolation Interlock

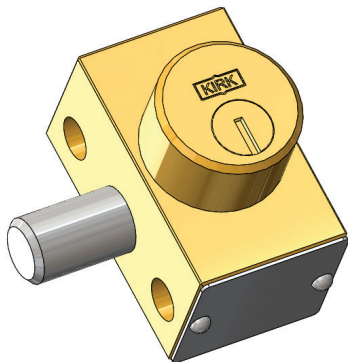

SD Series

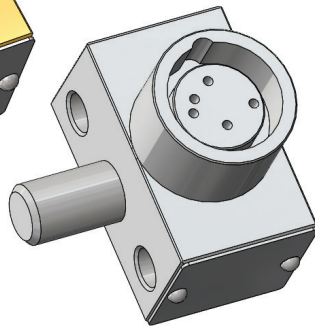

HD Series

KIRK Type U interlock is a key operated mechanical interlock that is suitable for the control of electrical switchgear. The standard unit comes with a stainless steel 5/8" diameter locking bolt with a throw or travel of 3/4". The locking bolt is used to control the rotation or movement of operating handles or toggles of electrical switchgear. Many suppliers of switchgear equipment have mounting provisions available for KIRK interlocks.

### OPERATION

KIRK Type U interlocks are mechanically operated and suitable for the control of electrical switchgear and to inhibit movement of cams, toggles, or levers.

#### Type U key operated mechanical isolation interlock

1

Key is trapped, bolt is withdrawn.

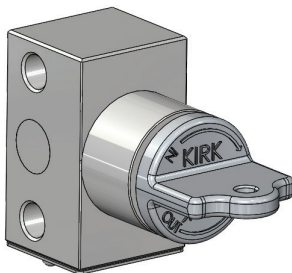

2

Change state of power, turn key, which extends bolt, releasing key.

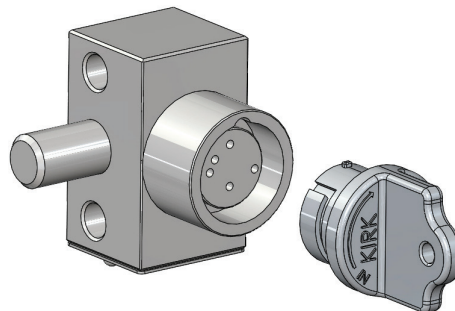

3

Bolt is now a physical barrier to switch and key is free to move to the next sequential interlock in the safety process.

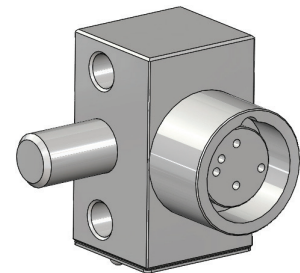

The length of the bolt is available in various lengths to suit each unique application. The travel of the bolt is always 3/4".

For HD multiple cylinder interlocks, all missing keys must be inserted and turned before any trapped keys can be released.

1 of 6

While every effort has been made to ensure the accuracy of the information provided, no liability can be taken for any errors or omission. Sentric Safety Group reserves the right to alter specifications and introduce improvements without prior notice.

U-Type U-EN (05-26)

# Type U

## Isolation Interlock



### USAGE

The KIRK Type U is designed for smaller spaces as the housing is narrower than the Type F.

KIRK bolt interlocks should be used on equipment as a physical barrier to electrical switches, push buttons, or levers. KIRK bolt interlocks ensure that once the equipment is switched into the desired position as defined by the end user's safety process and following the operations of the interlock, the switch is now blocked from changing state until the procedure is reversed.

 KIRK isolation interlocks are not designed to serve as an access interlock into hazardous areas.

No hazardous substances were used in the manufacturing of the product. The product can be disposed of in standard waste receptacles.

### INSTALLATION

The KIRK Type U is mounted from the side of the lock body. Proper installation of bolt interlocks is a critical element of a key interlock system. It is essential that each interlock be mounted so that the 5/8" lock bolt cannot be extended unless the equipment on which it is mounted is in the proper position/condition. After installation of the bolt interlocks, the complete interlock system should be tested sequentially by person(s) familiar with the entire system, the key sequence, and its intended purpose. Any problems or discrepancies must be corrected prior to energization.

SD series (brass) interlocks are supplied with a key in each cylinder. These keys are needed during installation of the interlocks. SD series (brass) bolt interlocks with multiple cylinders require the insertion of all keys before the lock bolt can be extended or withdrawn. Do not try to force a multiple cylinder interlock that does not have the correct keys fully inserted in every cylinder!

HD series (stainless steel) interlocks are not sold with keys. Keys must be ordered separately and may be required during the installation process.

 For all interlock systems to maintain system integrity, additional keys must be removed from the system and destroyed or retained by a responsible person. There should only be enough keys to operate the interlock system sequentially. Kirk Key Interlock Company will not be responsible for extra keys left in the interlock system.

 All interlocks and interlock systems must be installed by a competent and qualified person who has read and understood these instructions. Please retain this document in your technical files.

### MAINTENANCE

Kirk key interlocks should be periodically lubricated with a small amount of dry powder graphite. DO NOT use oil or grease of any type as these will collect dirt and impede the proper operation of the lock cylinder.

SD SERIES: Apply a small amount of graphite to the key and insert the key into the lock cylinder. Work the key in an out and turn the key several times in order to distribute the graphite inside the lock cylinder.

HD SERIES: Apply a small amount of graphite behind the inner turn shaft. Insert and turn the key a few times in order to distribute the graphite below the lock cylinder.

Protective covers for most products are also available as accessories. Covers can be utilized to protect the lock cylinders when located outdoors or in a demanding environment.

KIRK offers a Graphite Lubrication kit (part# GL-1) complete with instructions for use.

2 of 6

While every effort has been made to ensure the accuracy of the information provided, no liability can be taken for any errors or omission. Sentric Safety Group reserves the right to alter specifications and introduce improvements without prior notice.

U-Type U-EN (05-26)

# Type U

## Isolation Interlock



### TECHNICAL DATA

| Type U                       | SD Series   | HD Series       |
|------------------------------|---|-----------------|
| <b>Interlock Housing</b>     | Brass   | Stainless Steel |
| <b>Cylinder Housing</b>      | Brass   | Stainless Steel |
| <b>Plug/Inner Turn Shaft</b> | Brass   | Stainless Steel |
| <b>Key Material</b>          | Nickel-Silver   | Stainless Steel |
| <b>Key Style</b>             | 7-Pin Tumbler   | Dowel Pin       |
| <b>Lock Bolt</b>             | Stainless Steel   | Stainless Steel |
| <b>Type of Mounting</b>      | "Mounted through the side or back of the housing using suitable fasteners. Refer to drawing for details." |                 |
| <b>Temperature Ratings</b>   | -65F to +250F   | -65F to +700F   |
| <b>Weight</b>                | 1.68 pounds   | 1.47 pounds     |

\* Weight based on product with 1 cylinder, 0" bolt length, no key, accessories, or mounting hardware

### APPLICATION

The Type U interlocks are used as part of safety systems suitable for the control of electrical switchgear.

The interlock application scheme 1 is to prevent the opening of switch A when breaker B is closed.

Initial system status: Power is on and Switch A and Breaker B are in the closed position. Key A-1 is held in Breaker B interlock.

To begin maintenance of switchgear system, open Breaker B and turn key A-1 in L-O (locked open) interlock on Breaker B to lock open. Key A-1 is now free. Insert key A-1 into L-C (locked closed) interlock on Switch A and turn and unlock. Open Switch A and key A1- is now trapped.

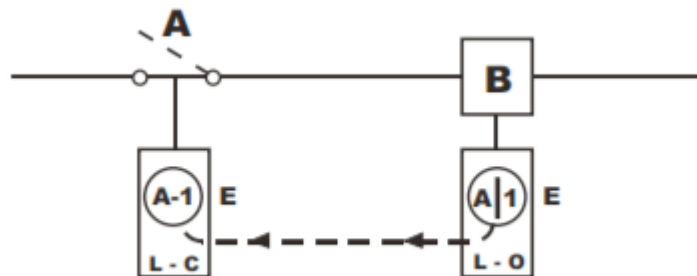

# Type U

## Isolation Interlock



### DRAWING

Dimensions: in inches

### SD Series Type U

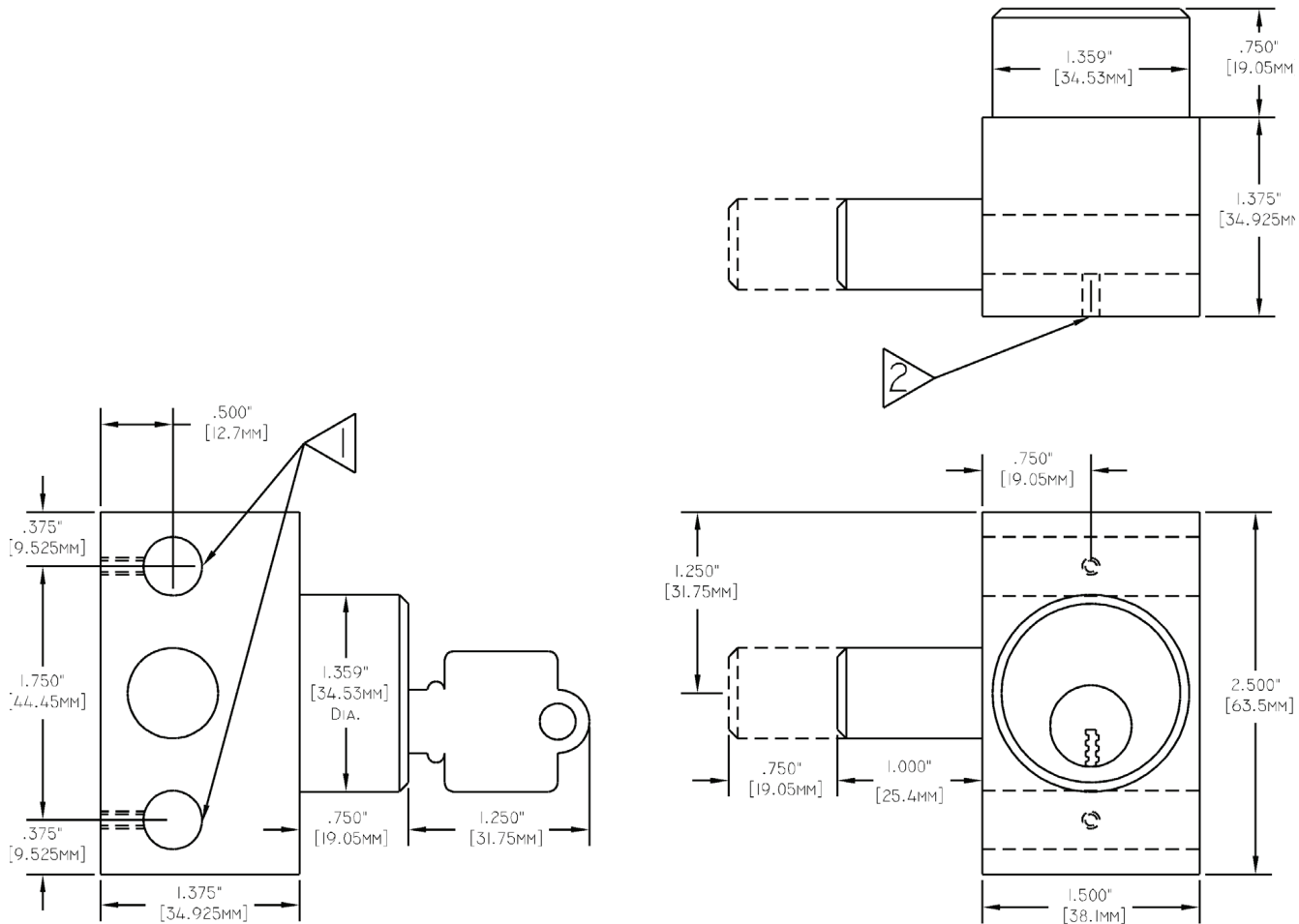

#### NOTES:

- 1) 0.4062" (10.32mm) holes for mounting bolts.
- 2) 10-32 tapped holes (2) places.

# Type U

## Isolation Interlock



### DRAWING

Dimensions: in inches

### HD Series Type U

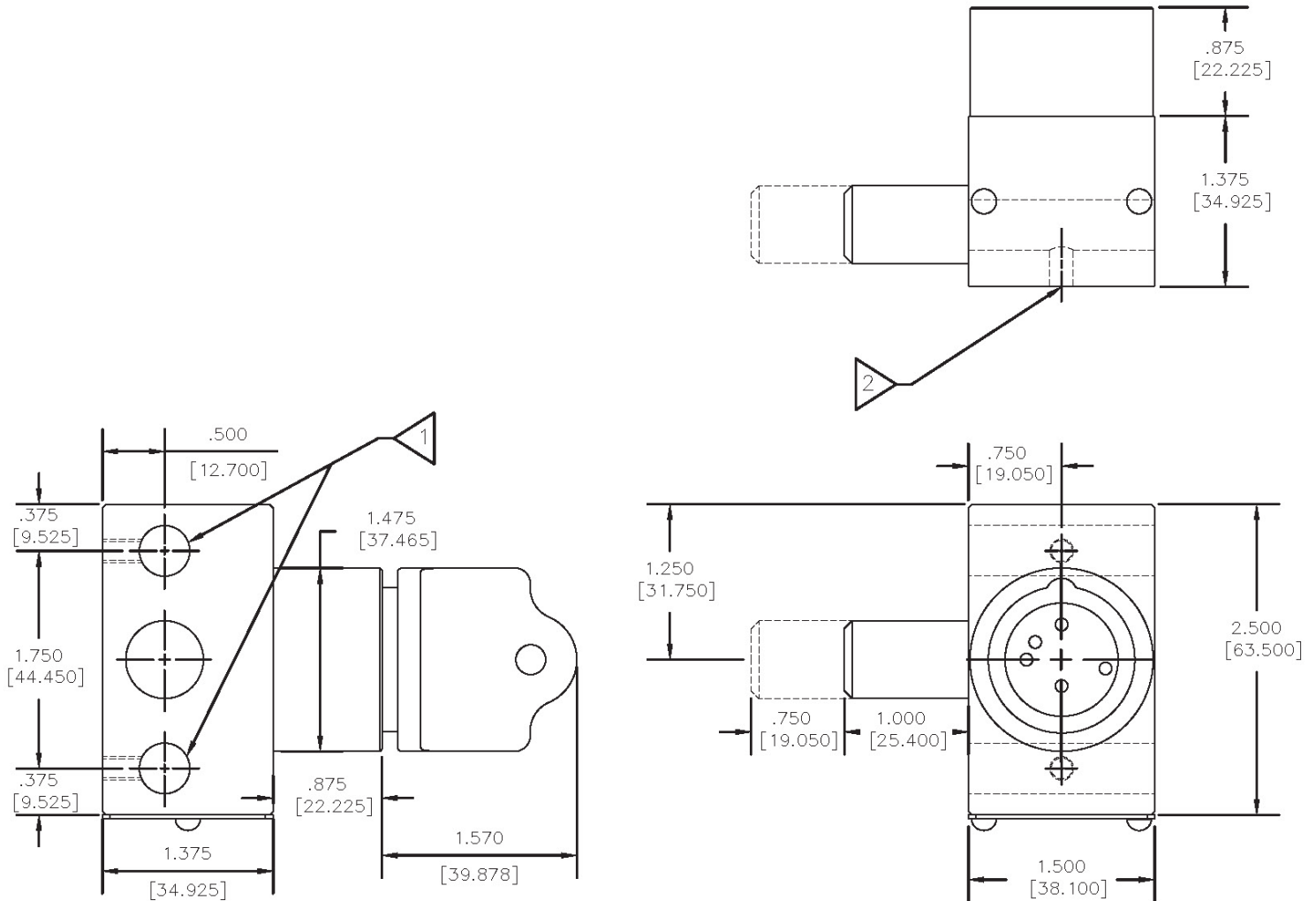

#### NOTES:

- 1) 0.4062" (10.32mm) holes for mounting bolts.
- 2) 10-32 tapped holes (2) places.

# Type U

## Isolation Interlock



### ORDER INFORMATION

|             |          |          |          |          |          |          |          |          |          |           |           |           |           |           |
|-------------|----------|----------|----------|----------|----------|----------|----------|----------|----------|-----------|-----------|-----------|-----------|-----------|
|             | <b>1</b> | <b>2</b> | <b>3</b> | <b>4</b> | <b>5</b> | <b>6</b> | <b>7</b> | <b>8</b> | <b>9</b> | <b>10</b> | <b>11</b> | <b>12</b> | <b>13</b> | <b>14</b> |
| Part number |          | U        | L        | o        |          |          |          |          |          | S         |           |           |           |           |

| 1       | Series   | K - SD Series (brass)              |   |                   |               | S - HD Series (stainless)  |   |           |                 |
|---------|--|------------------------------------|---|-------------------|---------------|--|---|-----------|-----------------|
| 5, 6, 7 | <b>Bolt Projection</b><br>(in withdrawn position)<br><br>Maximum bolt projection for both series is 7" | o                                  | o | o                 | 0", 0 mm      | 1  | o | o         | 1", 25.4 mm     |
|         |  | o                                  | 2 | 5                 | 1/4", 6.4 mm  | 1  | 2 | 5         | 1-1/4", 31.7 mm |
|         |  | o                                  | 3 | 7                 | 3/8", 9.5 mm  | 1  | 3 | 7         | 1-3/8", 34.9 mm |
|         |  | o                                  | 5 | o                 | 1/2", 12.7 mm | 1  | 5 | o         | 1-1/2", 38.1 mm |
|         |  | o                                  | 6 | 2                 | 5/8", 15.8 mm | 2  | o | o         | 2", 50.8 mm     |
|         |  | o                                  | 7 | 5                 | 3/4", 19.1 mm | 3  | o | o         | 3", 76.2 mm     |
| 8, 9    | <b>Cylinder(s)</b>   | <b>SD Series - max cylinders 1</b> |   |                   |               | <b>HD Series - max cylinders 1</b>   |   |           |                 |
|         |  | 1                                  | o | = E 1 CYL         |               | 1  | o | = E 1 CYL |                 |
|         |  | 1                                  | 1 | = W 1 CYL         |               | 1  | 1 | = W 1 CYL |                 |
| 10      | <b>Stamp Key Interchange</b><br>max. 5 alphanumeric characters   | S = Yes                            |   |                   |               | HD Series Stamp key interchange on Key only, unless flip cover is selected                                       |   |           |                 |
| 11      | <b>Opposite Hand</b>   | — = No                             |   | H = Opposite Hand |               | Opposite hand not available for HD Series  |   |           |                 |
| 12      | <b>Protective Covers</b><br>see protective covers data sheet   | — = No                             |   | C = Push On       | F = Flip Open | — = No F = Flip Open with LOTO provision   |   |           |                 |
| 13      | <b>Mounting Bolts</b><br>see mounting bolt data sheet  | — = No                             |   | T = Tamperproof   |               |  |   |           |                 |
| 14      | <b>Roll Pin</b>  | — = No                             |   | L = 3" Roll Pin   |               | Minimum bolt length 0.37" required when adding a roll pin. Specify orientation at time of order, 'A' is default. |   |           |                 |

**Roll Pin:**  
Bolt locks can be ordered with a 3" pressed-in mechanical extension (Roll Pin). Roll Pins may be used when a standard bolt is not capable of interfering/blocking a device as intended.

By specifying a Roll Pin the 'Pin Up' (A) orientation will be chosen by default.

Please contact your Kirk representative for custom orientations.

Example of F Lock with Roll Pin

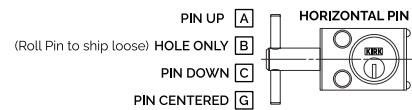

Kirk Key Interlock Company LLC  
9048 Meridian Circle, NW, North Canton, OH 44720, USA  
Tel: +1 234.209.9301 Email: sales@kirkkey.com

6 of 6

While every effort has been made to ensure the accuracy of the information provided, no liability can be taken for any errors or omission. Sentric Safety Group reserves the right to alter specifications and introduce improvements without prior notice.

U-Type U-EN (05-26)